



## REQUEST TO EXHIBIT - SUBMISSION FORM

### Instructions

The Town of Newmarket has two venues housing three gallery exhibition spaces. The two Serpa Galleries and the Community Gallery are located at Newmarket Old Town Hall (460 Botsford Street), where they can be booked separately or together. The 395 Executive Gallery is located at the Town of Newmarket Municipal Offices (395 Mulock Drive).

Applicants must indicate their preferred space. Due to the variations of the gallery spaces, applicants must read the Exhibit information thoroughly to select which space best suits their needs and acknowledge by signature that they have read the entire form.

Submissions are accepted on an ongoing basis and are reviewed quarterly by representatives of the curatorial team. Applicants will receive a reply within 3-4 months via email. Exhibitions are generally planned 1-2 years in advance.

Submissions are to be sent to [submissions@newmarket.ca](mailto:submissions@newmarket.ca)

### REQUEST TO EXHIBIT SUBMISSION FORM

Name: \_\_\_\_\_ City: \_\_\_\_\_

Province: \_\_\_\_\_ Email: \_\_\_\_\_

Phone: \_\_\_\_\_ Website: \_\_\_\_\_

Please Note: If you are filling out this Form with the intent to propose a group show, one individual must fill out all information and will be the point of contact for curatorial team going forward.

<b>Application Type:</b>	<b>Group submission</b>	<b>Independent submission</b>
<b>Gallery Requested:</b>	Old Town Hall (OTH) Serpa Galleries	OTH Community Gallery
	Municipal Offices 395 Executive Gallery	

**I have read and understood the Request to Exhibit Form and the Hanging Requirements document.**

**I am submitting a completed application with all requested items.**

Signature: \_\_\_\_\_ Date: \_\_\_\_\_

*Please submit this page with your application and the requested items.*

## EXHIBITION VENUES

### 395 Executive Gallery - Town of Newmarket Municipal Offices

The 395 Executive Gallery is located at the Municipal Offices (395 Mulock Drive). This space features approximately 45 feet of wall hanging space. This gallery is perfect for solo shows for those who have a smaller body of work or groups/collectives looking for their first show. The gallery uses traditional hanging mechanisms (screws), please refer to the attached **Hanging Requirements** document for more information.

Individual artists should have minimum 10-15 pieces of completed artwork before applying. Group shows with minimum 10 to maximum 20 artworks are the ideal size for this space. This space is programmed for 2 exhibitions per year. Artists need to be compliant with hanging works for approximately 5-6 months in this space.

**All works must be received hanging ready.** The gallery can accommodate 2D works only.

Gallery Hours:

Monday	8:30 a.m. to 4:30 p.m.
Tuesday	8:30 a.m. to 4:30 p.m.
Wednesday	8:30 a.m. to 4:30 p.m.
Thursday	8:30 a.m. to 4:30 p.m.
Friday	8:30 a.m. to 4:30 p.m.
Saturday	C L O S E D
Sunday	C L O S E D
Holidays	C L O S E D

Please refer to the attached Hanging Requirements.

### Serpa Galleries - Newmarket Old Town Hall

The Serpa Galleries are approximately 1957 sq ft and are located on the main floor of Newmarket Old Town Hall [OTH] (460 Botsford Street). The galleries are equipped with moveable art panels (4 ft wide x 9 ft tall) that run along a ceiling track system to allow for creative use of the space. The gallery uses two hanging systems, traditional hanging mechanisms (screws) on the moveable art panels and a 'hook and cable' system on the perimeter walls. Please refer to the attached **Hanging Requirements** document for more information.

Individual artists should have minimum 25 pieces of completed artwork before applying. Group shows of minimum 25 to maximum 40 artworks are the ideal size for this space. Typically, 6 exhibits are planned per year, and ideally exhibits are 2 months in length.

Gallery Hours:

Monday	Closed or by advance appointment
Tuesday	10 a.m. to 8:30 p.m.
Wednesday	10 a.m. to 4 p.m.
Thursday	10 a.m. to 8:30 p.m.
Friday	10 a.m. to 4 p.m.

Saturday 10 a.m. to 4 p.m.  
Sunday C L O S E D  
Holidays C L O S E D

PLEASE NOTE: All OTH galleries are **multi purpose spaces**, and as such there may be closures due to private events. Updated gallery hours of operations are found at [www.newmarket.ca/OTHexhibits](http://www.newmarket.ca/OTHexhibits)

**All works must be received hanging ready.** The gallery can accommodate 2D works, 3D works (large and small scale), and a range of multi media works. If you have a question about the feasibility of your work, please contact Logan Bales [lbales@newmarket.ca](mailto:lbales@newmarket.ca)

Please refer to the attached Hanging Requirements.

## Community Gallery - Newmarket Old Town Hall

The Community Gallery located at OTH is a smaller gallery space that is separate but attached to the Serpa Galleries. **This space can be booked separately, or in addition to the Serpa Galleries.** The Community Gallery is ideal for youth and emerging artists, or for small exhibitions when booked on its own. The Community Gallery is approx. 320 sq ft and uses a 'hook and cable' hanging system. Please refer to the attached **Hanging Requirements** document for more information.

Individual artists should have a minimum of six pieces of completed artwork before applying. Group shows of six to 10 artworks are ideal for this gallery. Exhibits are ideally two months in length and are accommodated subject to availability.

Gallery Hours:

Monday Closed or by advance appointment  
Tuesday 10 a.m. to 8:30 p.m.  
Wednesday 10 a.m. to 4 p.m.  
Thursday 10 a.m. to 8:30 p.m.  
Friday 10 a.m. to 4 p.m.  
Saturday 10 a.m. to 4 p.m.  
Sunday C L O S E D  
Holidays C L O S E D

PLEASE NOTE: All OTH galleries are **multi purpose spaces**, and as such there may be closures due to private events. Updated gallery hours of operations are found at [www.newmarket.ca/OTHexhibits](http://www.newmarket.ca/OTHexhibits)

**All works must be received hanging ready.** The gallery can accommodate 2D works, 3D works (large and small scale), and a range of multi media works. If you have a question about the feasibility of your work, please contact Logan Bales [lbales@newmarket.ca](mailto:lbales@newmarket.ca)

Please refer to the attached Hanging Requirements.

## WHAT TO SUBMIT

### Entry for Ongoing Submissions - **Independent**

1. Completed Exhibit Submission Form indicating the space in which you wish to display.
2. Current Curriculum Vitae (Microsoft Word or PDF) and brief bio with photo.
3. Artist Statement outlining the context, media, and themes present in your work. Please specify if your works require special equipment (technology, video, projection, display cases, plinths, sound, etc.). Maximum 750 words (Microsoft Word or PDF).
4. Minimum 7 digital JPG images and/or 3 videos of proposed work or current work. Photo and video specifications are outlined in the Image List template, all submitted media should be labeled as: 01\_LastName\_Titleofwork\_date
5. Corresponding image list (use template attached)

### Entry for Ongoing Submissions – **Group**

1. Completed Exhibit Submission Form
2. Current Curriculum Vitae (Microsoft Word or PDF) for each participating artist.
3. Exhibition proposal including the themes, concept, and context the proposed show aims to articulate. Please also specify the media shown and if the artworks require special equipment (technology, video, projection, display cases, plinths, sound, etc.). Maximum 1000 words (Microsoft Word or PDF).
4. Artist Statement and brief bio of each of the participating artists. Maximum 500 words (Microsoft Word or PDF).
5. Minimum 3 digital JPEG images and/or 3 videos of each artist's proposed or current work. Photo and video specifications are outlined in the Image List template, all submitted media should be labeled as: 01\_LastName\_Titleofwork\_date
6. Corresponding image list (use template attached) all artists can be added to the same template. When numbering artworks, please ensure each artist's work begins at "01".

## Image List

Please use the following Image List template. Artworks submitted in your application can either depict work you intend to exhibit or reflect your current artistic practice.

Image Requirements	Video Requirements
<ul style="list-style-type: none"> <li>● <input type="checkbox"/> JPEG file format</li> <li>● <input type="checkbox"/> Number and label each image as follows, example: 01_LastName_Titleofwork_date</li> <li>● <input type="checkbox"/> Images may not exceed 300 dpi and should not exceed 1024 x 768 pixels</li> <li>● <input type="checkbox"/> Images must be sent to <a href="mailto:submissions@newmarket.ca">submissions@newmarket.ca</a></li> </ul>	<ul style="list-style-type: none"> <li>● <input type="checkbox"/> Mov or avi file format</li> <li>● <input type="checkbox"/> Number and label each image as follows, example: 01_LastName_Titleofwork_date</li> <li>● <input type="checkbox"/> Video can be sent directly to <a href="mailto:submissions@newmarket.ca">submissions@newmarket.ca</a> or direct links to YouTube or website are accepted, please indicate in Image List</li> </ul>

### Image List for Independent or Group Submission - IMAGES

\*Please add rows as needed

Image No.	Artist	Title	Medium	Dimensions, year

## Image List for Independent or Group Submission - VIDEO

\*Please add rows as needed

Image No	Artist	Title	Medium, year	Website/YouTube link (if applicable)

# Hanging Requirements

## 395 Executive Gallery - Town of Newmarket Municipal Offices

The 395 Executive Gallery uses a traditional hanging system (screws). Walls are patched and painted after each exhibit. This gallery space can only accommodate 2D works; all works must be hanging ready.



Figure 1 and 2 Exhibition: Mulock Farms: Artist Preserve History. Artist shown (Left to Right): Society of York Region Artists- Mathab Abdollahi, Mikhail Nikitsenka, Robert McAfee, Nancy Newman, Sharon Neilson, Catherine Fairs, Lucy Quintero, and Carol Walthers



## Serpa Galleries - Newmarket Old Town Hall

The Serpa Galleries use two methods of hanging artwork. The first system is referred to as a 'hook and cable' system. This system is used on the **perimeter walls of the galleries**. NO holes are to be made on the perimeter walls; the walls are not patched nor painted after each installation.

Newmarket Old Town Hall provides the 'hooks and cables' for artwork to be hung. Below are images and instructions on how to use the hooks (see figure 1 and 2), please note that not all mounting mechanisms are compatible with the hooks, **wire backing and large D-rings** are the best and most secure method of mounting your work when using the hook and cable system. We cannot guarantee that other mounting systems will be compatible with our hooks.

Mini Hook: CAPACITY 12 lbs. 5.0 Kg with steel cables

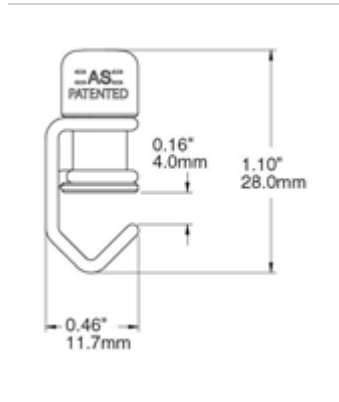

(Figure 1, Mini Hook and steel cable)

Self-Gripping Hook: CAPACITY 33 lbs. 15.0 Kg with steel cable

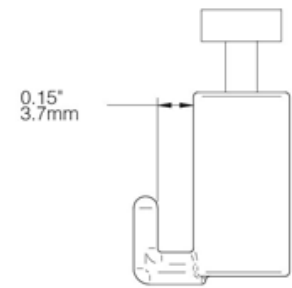
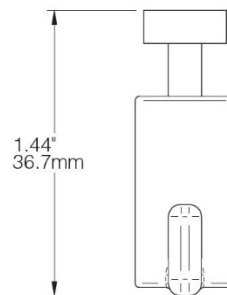

(Figure 2, Self-Gripping Hook and steel cable)

The second method is the most versatile. The galleries are equipped with moveable art panels, the mobile panels allow for interchangeable set ups in the gallery space. There are 16 art panels on each side of the gallery. Each art panel is 4ft wide by approximately 9ft tall. The art panels can be moved along a ceiling track system and are capable of being drilled and screwed directly into as they are patched and painted after exhibitions. They have the most flexibility for exhibitions.

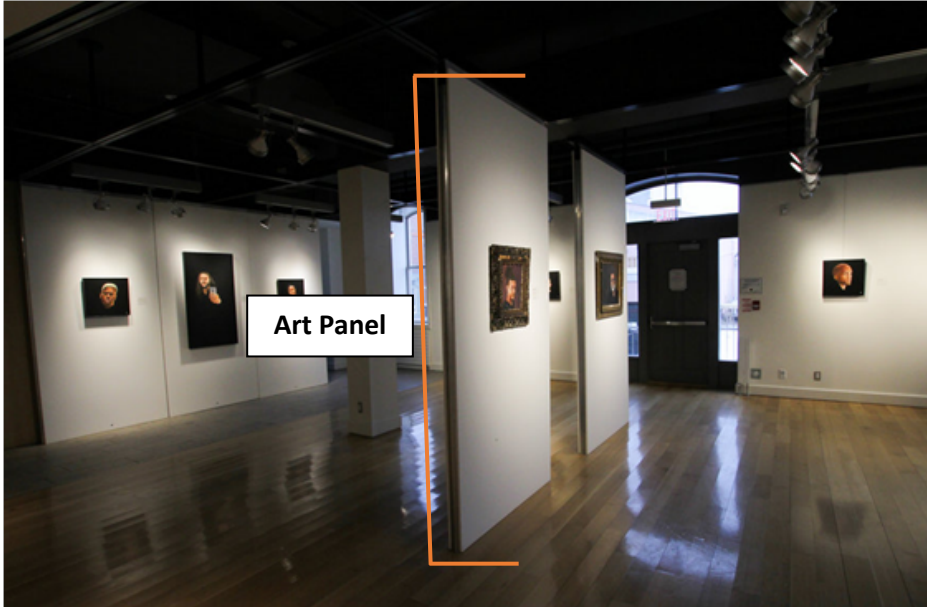

Figure 3 Exhibition: *Still I Rise: Stories of Strength, Courage, and Innovation*. Artist shown: Gordon Shadrach

### Previous Exhibitions in the Serpa Galleries



Figure 4 Exhibition: *Ted Fullerton: Figure in a Landscape*. Artist shown: Ted Fullerton



Figure 5 Exhibition: *Ted Fullerton: Figure in a Landscape*. Artist shown: Ted Fullerton

## Community Gallery - Newmarket Old Town Hall

The Community Gallery uses only a 'hook and cable' system for hanging artworks. This system is used on the **perimeter walls of the galleries**. NO holes are to be made in the perimeter walls; the walls are not patched or painted after each installation.

Newmarket Old Town Hall provides the 'hooks and cables' for artwork to be hung. Below are images and instructions on how to use the hooks (see figure 1 and 2), please note that not all mounting mechanisms are compatible with the hooks, **wire backing and large D-rings** are the best and most secure method of mounting your work when using the hook and cable system. We cannot guarantee that other mounting systems will be compatible with our hooks.

Mini Hook: CAPACITY 12 lbs. 5.0 Kg with steel cables

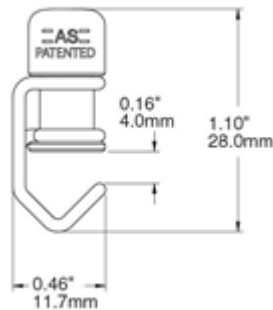

(Figure 1, Mini Hook and steel cable)

Self-Gripping Hook: CAPACITY 33 lbs. 15.0 Kg with steel cable

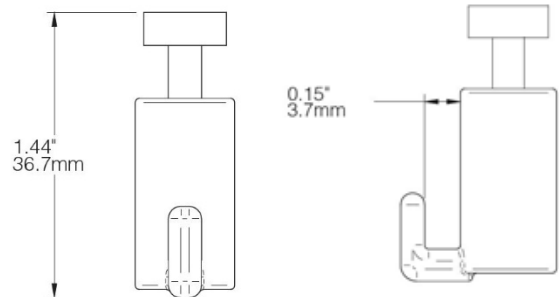

(Figure 2, Self-Gripping Hook and steel cable)

## Previous Exhibitions in the Community Gallery (OTH)



*Figure 4 Exhibition: Newmarket Juried Art Show. Artists shown (Left to Right): Andrew Kulin, Teresa Dunlop, Sheila Dantzer, Fariba Kalantari, and Kathleen Pistor*



*Figure 5 Exhibition: Ted Fullerton: Figure in a Landscape. Artist shown: Ted Fullerton*